

Aggregate



Specifications

Payload	Aggregates/Asphalt
----------------	--------------------

Dimensions

Length	10.058 m
Width	2.5 m
Overall Height	3.15 m
Volume	29.05 m ³
Weight	7760 kg

Running Gear

Axles/Suspensions	SAF Off Road
ABS	2S/2M WABCO EU system
Brake Type	Disc
Brake System	WABCO EBS
Tires	385/65R 22.5 Continental HT3
Landing Gear	MV Plastecnic Aluminum Drop Leg

Body

Side Panels	Aluminium patented THINWALL® horizontal hollow-core extruded panels - New Generation Heavy-Duty
Top Rail	Integrated 177.8 mm top rail
Front Access Door	Sealed
Moving Floor	KEITH® WALKING FLOOR® flat top steel V with Titan Moving Side Slat
Mud flaps	Plastic - spray suppress flap
Lights	LED - Truck Lite
Rear Door	Hydraulic, hinged, overslung door, 22° slope
Bumper	Retractable underrun with mudguard



TITAN 10.058 m 3-Axle Aluminium THINWALL® KEITH® WALKING FLOOR® Flat Top Steel V



Popular Options & Upgrades

Brake Type	Drum
Lift Axle	SAF lift kit on leading axle
Tarp	Hydraulic side roll
Clean-Out System	TITAN Trailers Aggregate V-Plow
Remote Control	A wireless remote control system to run components (floor, tarp, plow, door)
Storage	Plastic storage box
Access	Pull out ladder for easier access into rear of the trailer
Lights	Additional lights along top of sidewall, internal work light
Camera	Reverse camera • Internal camera for loading and unloading
Bumper	Retractable underrun with mudguard
Additional Safety Feature	Reverse beeper
Paint	Trailers can be custom painted

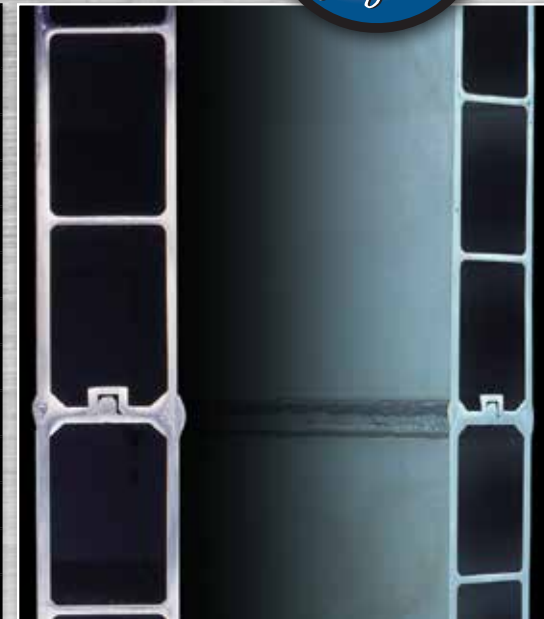

JOB PROFILE

- Maximize your profit with larger load capacity, fuel efficiency and minimal downtime • Effective performance and customer satisfaction require rapid on and off-loading with reliability
- Long-term return-on-investment means low maintenance costs plus maximum residual value

KEY FEATURES

- The patented THINWALL® panel features a horizontal tongue-in-groove joint that allows 100% machine welding inside AND outside for end-to-end strength.
- KEITH® WALKING FLOOR® • Aluminium coupler assembly with bolt in kingpin • Aluminium frame/floor assembly • Moving side slat • Integrated top rail
- Plastic liner along lower portion of sidewall • Single top cross bar

HEAD OFFICE

1129 Hwy #3, R.R. #3
 Delhi, Ontario, Canada N4B 2W6
 Tel: 519-688-4826 Fax: 519-688-6453
 e-mail: info@titantrailers.com

EUROPEAN OFFICE

Bolckow Industrial Estate,
 Grangetown, Middlesbrough
 Tel: + 44 (0) 1642 460660

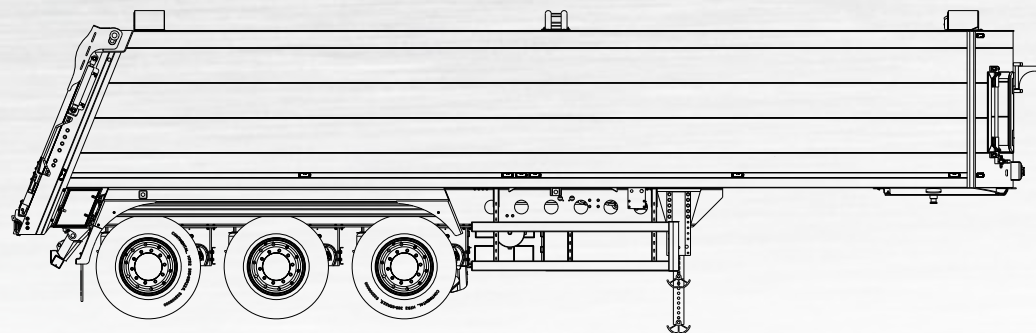

KEITH® and WALKING FLOORS® are worldwide registered trademarks of KEITH Mfg. Co.